



DISC HARROW

BUSH HOG®

1D / 2D / 3D SERIES

PUBLISHED 09/11

MATERIAL HANDLING PARTS MANUAL

PARTS MANUAL SECTION 23



An Operator's Manual was shipped with the equipment . The Operator's Manual is an integral part of the safe operation of this machine and must be maintained with the unit at all times. **READ, UNDERSTAND, and FOLLOW** the Safety and Operation Instructions contained in this manual before operating the equipment. If the Operator's Manual is not with the equipment, contact your dealer or Bush Hog to obtain a Free copy before operating the equipment.

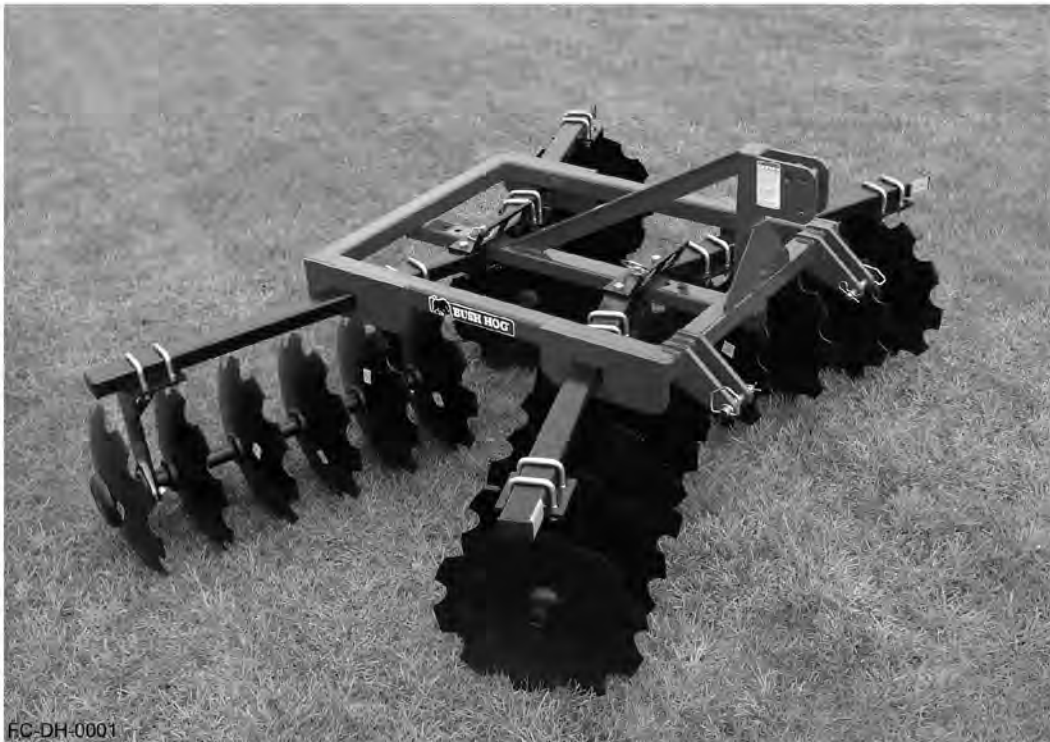

FC-DH-0001

BUSH HOG®

2501 Griffin Ave.
Selma, AL 36703
334-874-2700

www.bushhog.com

¡ATENCIÓN!
LEA EL INSTRUCTIVO



Si No Lee Ingles, Pida
Ayuda a Alguien
Que Se Lo Lea Para Que le
Traduzca Las
Medidas de Seguridad

©2011 Alamo Group Inc.

A MEMBER OF THE
ALAMO GROUP
ALWAYS ON THE CUTTING EDGE®

PARTS ORDERING GUIDE

The following instructions are offered to help eliminate needless delay and error in processing purchase orders for the equipment in this section.

1. The Parts Section is prepared in logical sequence and grouping of parts that belong to the basic machine featured in this manual. Part Numbers and Descriptions are given to help locate the parts and quantities required.
2. The Purchase Order must include the name and address of the person or organization ordering the parts, who should be charged, and if possible, the serial number of the machine for which the parts are ordered.
3. The Purchase Order must clearly list the quantity of each part, the complete and correct part number (be sure to include all periods), and the basic name of the part.
4. The Manufacturer reserves the right to substitute parts where applicable.
5. Some parts are unlisted items which are special production items not normally stocked and are subject to special handling. Request a quotation for such parts before sending a Purchase Order.
6. The Manufacturer reserves the right to change prices without prior notice.



For maximum safety and to guarantee optimum product reliability, always use genuine BUSH HOG Parts. The use of inferior replacement parts may cause premature or catastrophic failure which could result in serious injury or death. Direct any questions regarding parts to:

BUSH HOG
2501 Griffin Ave.
Selma, AL 36703
www.bushhog.com
Contact Us
800-304-2836



BUSH HOG®

LIMITED WARRANTY

Bush Hog warrants to the original purchaser of any new Bush Hog equipment, purchased from an authorized Bush Hog dealer, that the equipment be free from defects in material and workmanship for a period of one (1) year for non-commercial, state and municipalities' use and ninety (90) days for commercial use from date of retail sale. The obligation of Bush Hog to the purchaser under this warranty is limited to the repair or replacement of defective parts.

Replacement or repair parts installed in the equipment covered by this limited warranty are warranted for ninety (90) days from the date of purchase of such part or to the expiration of the applicable new equipment warranty period, whichever occurs later. Warranted parts shall be provided at no cost to the user at an authorized Bush Hog dealer during regular working hours. Bush Hog reserves the right to inspect any equipment or parts which are claimed to have been defective in material or workmanship.

DISCLAIMER OF IMPLIED WARRANTIES & CONSEQUENTIAL DAMAGES

Bush Hog's obligation under this limited warranty, to the extent allowed by law, is in lieu of all warranties, implied or expressed, **INCLUDING IMPLIED WARRANTIES OF MERCHANTABILITY AND FITNESS FOR A PARTICULAR PURPOSE** and any liability for incidental and consequential damages with respect to the sale or use of the items warranted. Such incidental and consequential damages shall include but not be limited to: transportation charges other than normal freight charges; cost of installation other than cost approved by Bush Hog; duty; taxes; charges for normal service or adjustment; loss of crops or any other loss of income; rental of substitute equipment, expenses due to loss, damage, detention or delay in the delivery of equipment or parts resulting from acts beyond the control of Bush Hog.

THIS LIMITED WARRANTY SHALL NOT APPLY:

1. To vendor items which carry their own warranties, such as engines, tires, and tubes.
2. If the unit has been subjected to misapplication, abuse, misuse, negligence, fire or other accident.
3. If parts not made or supplied by Bush Hog have been used in connection with the unit, if, in the sole judgement of Bush Hog such use affects its performance, stability or reliability.
4. If the unit has been altered or repaired outside of an authorized Bush Hog dealership in a manner which, in the sole judgement of Bush Hog, affects its performance, stability or reliability.
5. To normal maintenance service and normal replacement items such as gearbox lubricant, hydraulic fluid, worn blades, or to normal deterioration of such things as belts and exterior finish due to use or exposure.
6. To expendable or wear items such as teeth, chains, sprockets, belts, springs and any other items that in the company's sole judgement is a wear item.

NO EMPLOYEE OR REPRESENTATIVE OF BUSH HOG IS AUTHORIZED TO CHANGE THIS LIMITED WARRANTY IN ANY WAY OR GRANT ANY OTHER WARRANTY UNLESS SUCH CHANGE IS MADE IN WRITING AND SIGNED BY BUSH HOG'S SERVICE MANAGER, 2501 GRIFFIN AVE., SELMA, ALABAMA 36703.

Record the model number, serial number and date purchased. This information will be helpful to your dealer if parts or service are required.

MODEL NUMBER _____

SERIAL NUMBER _____

DATE OF RETAIL SALE _____

MAKE CERTAIN THE WARRANTY
HAS BEEN FILED WITH BUSH HOG
SELMA, ALABAMA

TABLE OF CONTENTS

DISC HARROWS

1D / 2D / 3D SERIES

1D SERIES

Frame and Related Parts.....	23-1-1
Disc Gangs and Related Parts	23-1-2, 23-1-3
Scrapers	23-1-4

2D SERIES

Frame and Related Parts.....	23-2-1
Disc Gangs and Related Parts	23-2-2, 23-2-3
Scrapers	23-2-4

3D SERIES

Frame and Related Parts.....	23-3-1
Disc Gangs and Related Parts	23-3-2, 23-3-3
Scrapers	23-3-4

DISC HARROW 1D SERIES FRAME AND RELATED PARTS

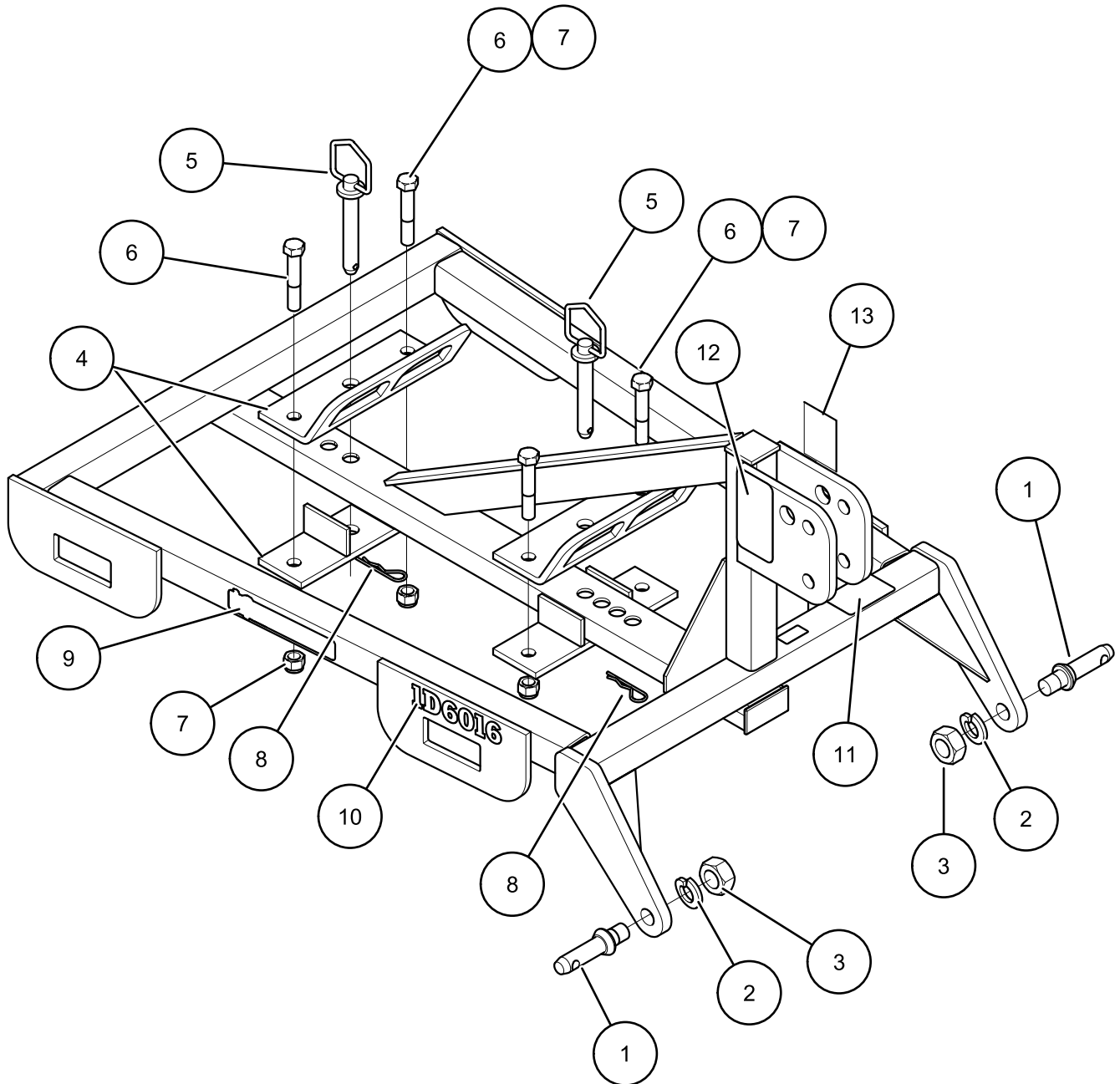

Ref. No.	Part No.	Description	Qty. Req'd.	Ref. No.	Part No.	Description	Qty. Req'd.
1	63765	Lift Pin Cat I	2	9	50062087	Logo Decal Bush Hog	3
2	15824	Lockwasher 7/8"	2	10	50069564	Model Decal 1D6016	2
3	44061BH	Hex Nut 7/8" UNF	2		50069565	Model Decal 1D6018	2
4	50069634	Angle Adjust Assy	2		50069566	Model Decal 1D7816	2
5	99343	Index Pin 3/4" x 4-1/2"	2		50069567	Model Decal 1D7818	2
6	-----	Capscrew 5/8" x 3-1/2"	4	11	00725746	Danger Decal	1
7	-----	Locknut 5/8"	4	12	50057097	Caution Decal	1
8	50005860	Hair Pin	2	13	90960BH	Warning Decal	1

DISC HARROW 1D SERIES DISC GANGS AND RELATED PARTS

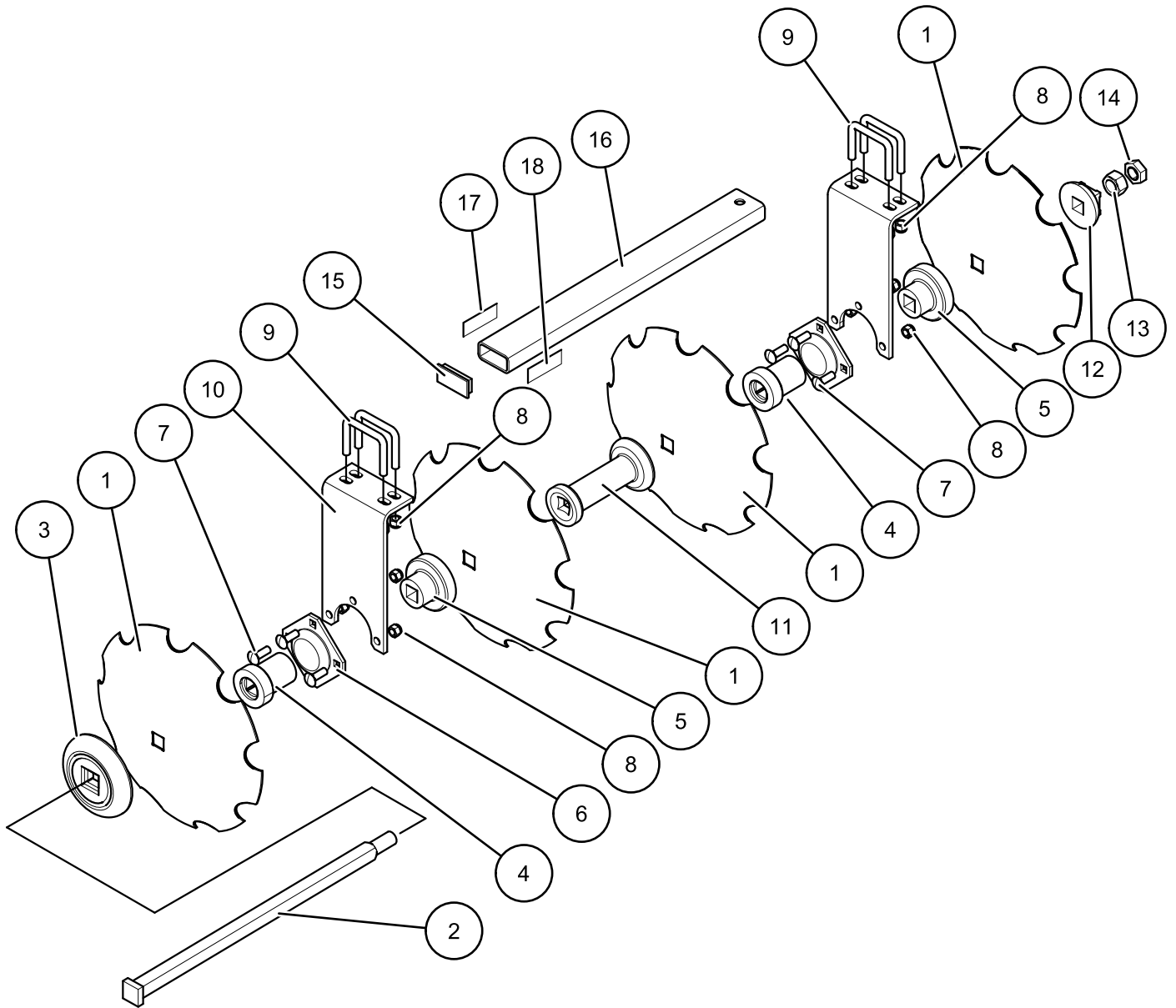

**DISC HARROW
1D SERIES
DISC GANGS AND RELATED PARTS**

Ref. No.	Part No.	Description	Qty. Req'd.
1	50069633	Disc Blade 16" Notched 1" Hole	1
	50069614	Disc Blade 18" Notched 1" Hole	1
2	50069620	Gang Bolt 1"x 26" for 4 Blade 7-1/2" Sp.	1
	50069621	Gang Bolt 1"x 31" for 4 Blade 9" Sp.	1
	50069625	Gang Bolt 1"x 21-1/2" for 3 Blade 9" Sp.	1
	50069617	Gang Bolt 1"x 34" for 5 Blade 7-1/2" Sp.	1
3	50069613	Washer (Disc End Cap)	1
4	50069611	Spacer 3-5/8" for 7-1/2" Spacing	1
	50069619	Spacer 5-1/8" for 9" Spacing	1
5	50069612	Spacer 2-3/8" for 7-1/2" and 9" Spacing	1
6	50069615	Bearing	1
7	-----	Carriage Bolt 1/2" x 1-1/2" Gr.5	24
8	-----	Locknut 1/2" Nyloc	40
9	50069591	U-Bolt 1/2" x 2" x 3"	16
10	50069636	Hanger Assy	8
11	50069610	Spacer 7-1/2" Spacing	1
	50069618	Spacer 9" Spacing	1
12	50069616	Washer (Nut End)	1
13	-----	Hex Nut 1"	1
14	-----	Jamb Nut 1" Hex Flat	1
15	50069640	End Cap	4
16	50069635	Gang Tube 26" 4 Blade 7-1/2" Sp.	1
	50065637	Gang Tube 32" 5 Blade 7-1/2" Sp.	1
	50069638	Gang Tube 37" 4 Blade 9" Sp.	1
	50069639	Gang Tube 20-1/2" 3 Blade 9" Sp.	1
17	50031213	Reflector, Red (Rear Gang Tubes)	2
18	50031212	Reflector, Amber (Front Gang Tubes)	2

DISC HARROW 1D SERIES DISC SCRAPERS AND RELATED PARTS

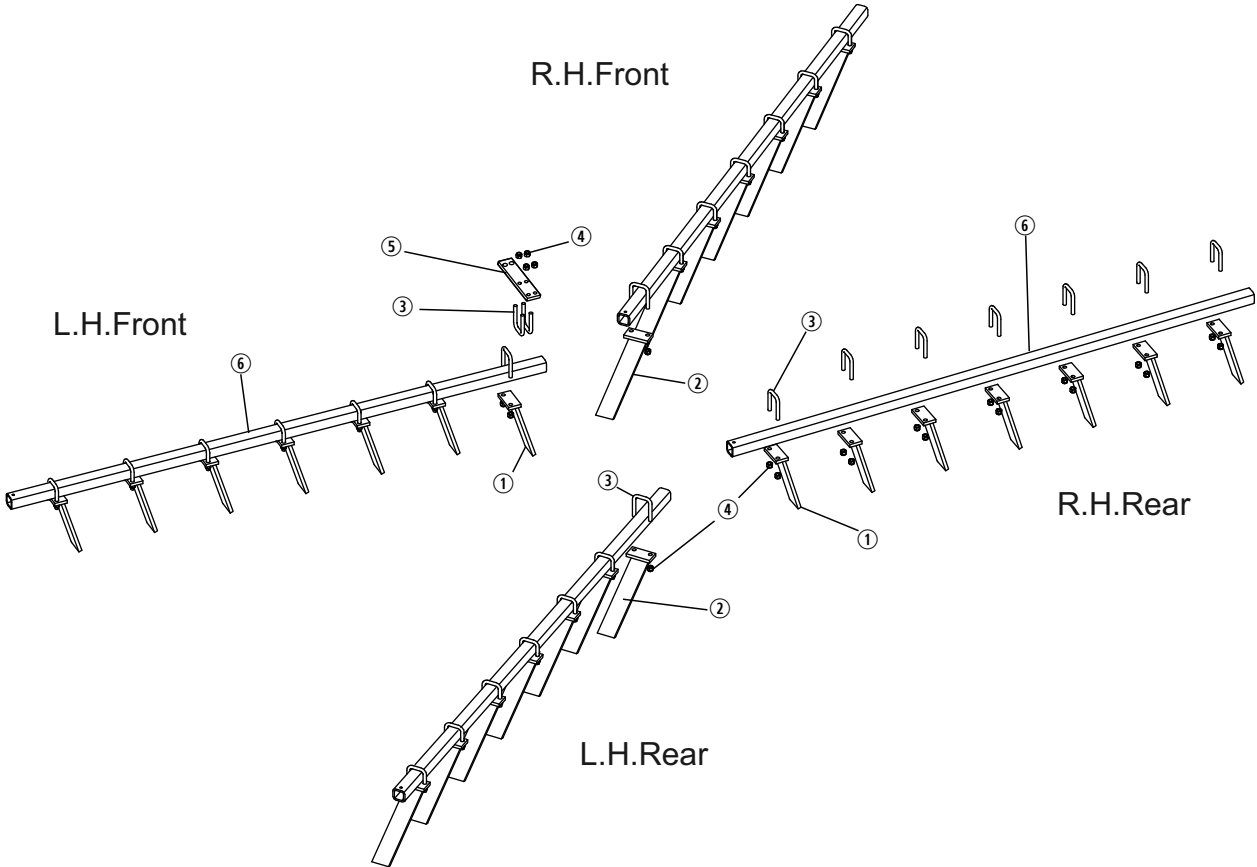

To Order a Complete Scraper Kit for a Complete Machine see the Whole Goods Price List.

Ref. No.	Part No.	Description	Qty. Req'd.
1	50071191	Scraper L.H. Front & R.H. Rear	A/R
2	50071192	Scraper R.H. Front & L.H. Rear	A/R
3	50071188	U-Bolt 3/8" x 1-5/8"	A/R
4	44624BH	Hex Nut 3/8" Nylock	A/R
5	50071195	Scraper Attach Plate	A/R
6	50071194	Scraper Mount Tube 1-1/2" Sq. x 35"	A/R
	50071196	Scraper Mount Tube 1-1/2" Sq. x 23"	A/R
	50071197	Scraper Mount Tube 1-1/2" Sq. x 27"	A/R

DISC HARROW 2D SERIES FRAME AND RELATED PARTS

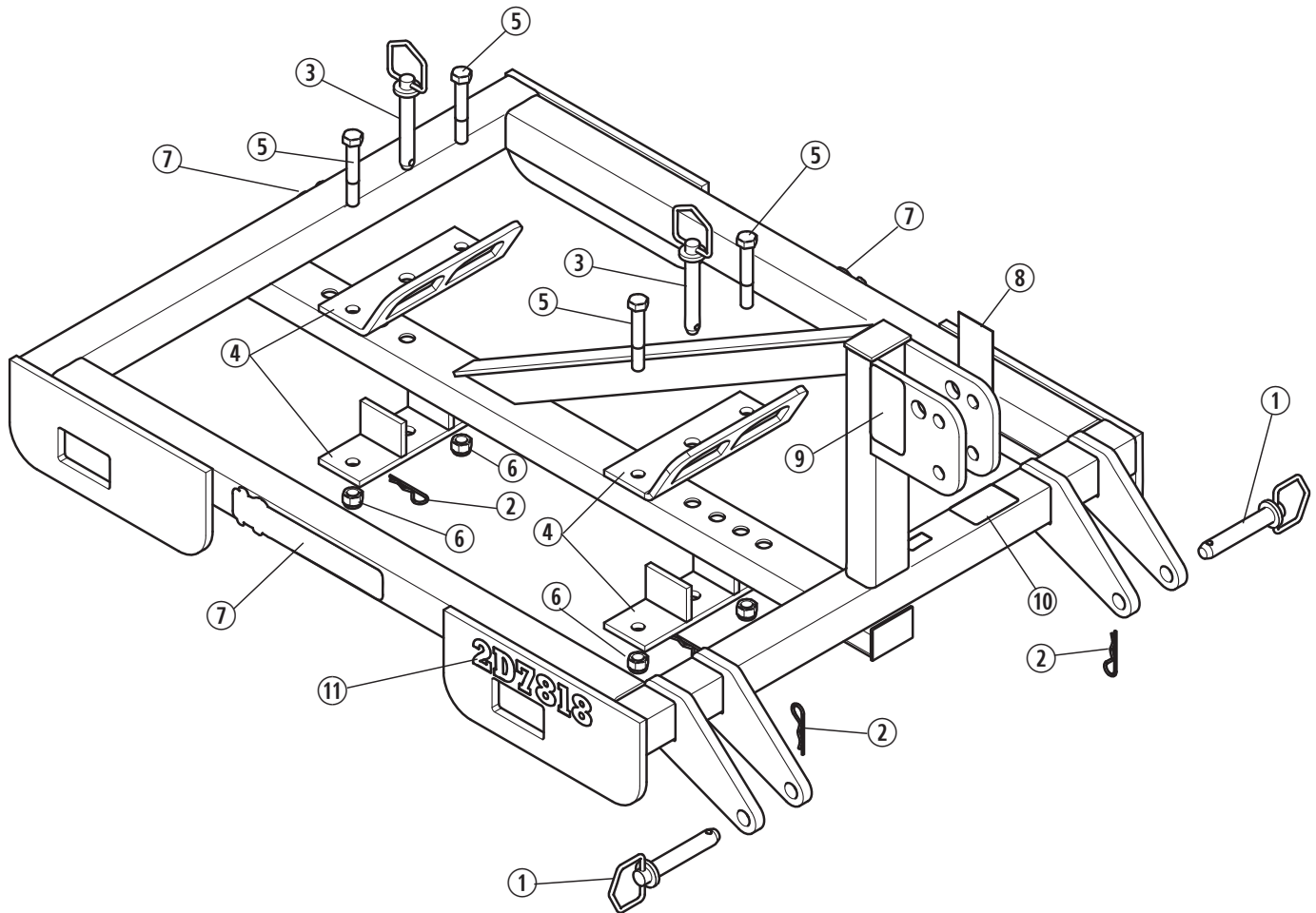

Ref. No.	Part No.	Description	Qty. Req'd.
1	95121	Hitch Pin 7/8" x 4 1/4"	2
2	50005860	Hair Pin .148 x 3	4
3	99343	Index Pin 3/4" x 4 1/2"	2
4	50069627	Angle Adj. Assy.	2
5	-----	Capscrew 5/8 x 4" Gr.5	4
6	-----	Locknut 5/8" Nyloc	4
7	50058089	Bush Hog Decal (Logo)	3
8	90960BH	Warning Decal	1
9	50057097	Caution Decal	1
10	00725746	Danger Decal	1
11	50069568	Model Decal 2D7818	2
	50069569	Model Decal 2D7820	2
	50069570	Model Decal 2D9618	2
	50069571	Model Decal 2D9620	2

DISC HARROW 2D SERIES DISC GANGS AND RELATED PARTS

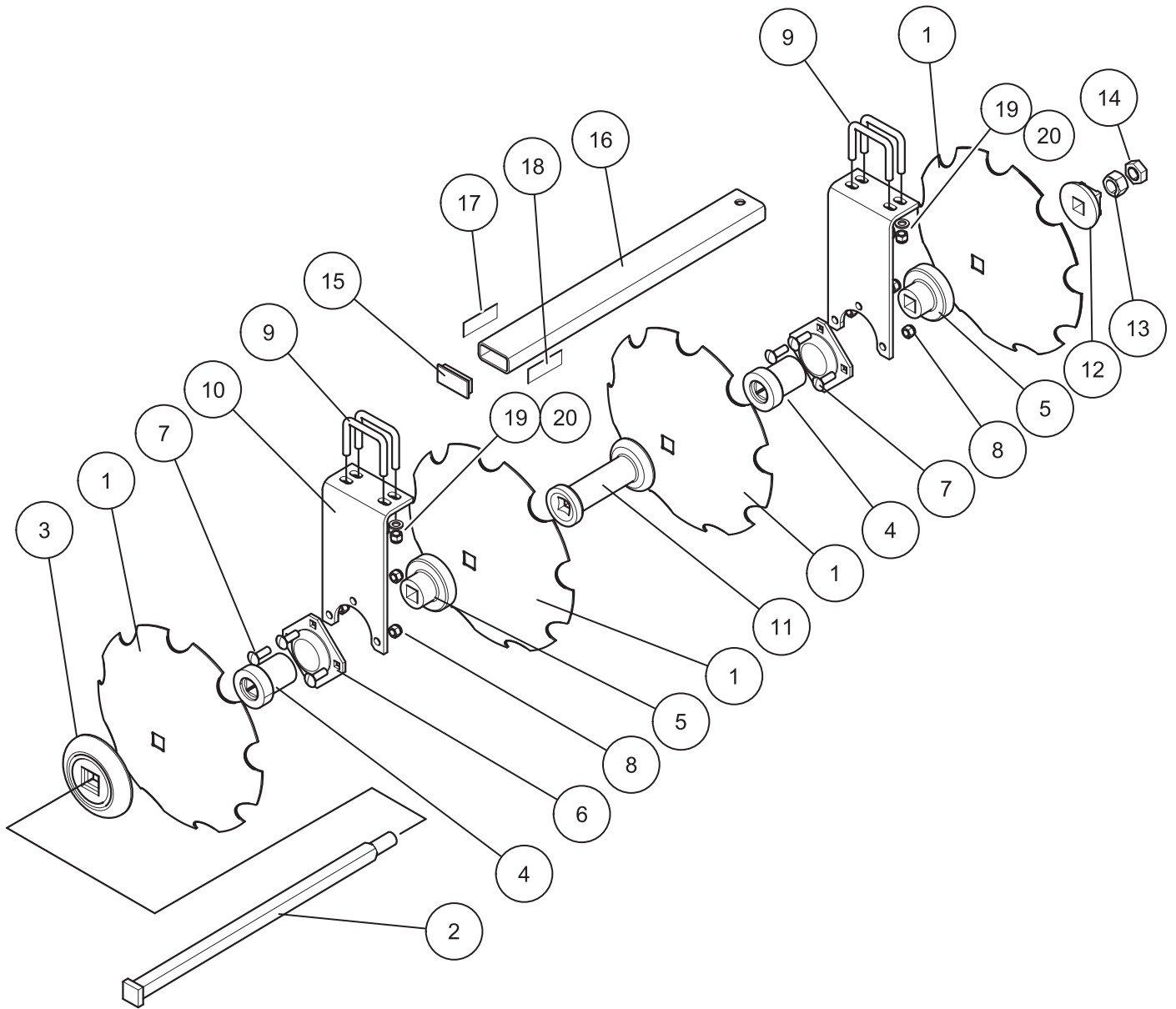

DISC HARROW 2D SERIES DISC GANGS AND RELATED PARTS

Ref. No.	Part No.	Description	Qty. Req'd.
1	50069623	Disc Blade 20" Notched 1" Hole	1
	50069614	Disc Blade 18" Notched 1" Hole	1
2	50069622	Gang Bolt 1"x 41" for 6 Blade 7 1/2" Sp.	1
	50069621	Gang Bolt 1"x 31" for 4 Blade 9" Sp.	1
	50069624	Gang Bolt 1"x 39 1/2" for 5 Blade 9" Sp.	1
	50069617	Gang Bolt 1"x 34" for 5 Blade 7 1/2" Sp.	1
3	50069613	Washer (Disc End Cap)	1
4	50069611	Spacer 3 -5/8" for 7 1/2" Spacing	1
	50069619	Spacer 5 -1/8" for 9" Spacing	1
5	50069612	Spacer 2 -3/8" for 7 -1/2" and 9" Spacing	1
6	50069615	Bearing	1
7	-----	Carriage Bolt 1/2" x 1-1/2" Gr.5	24
8	-----	Locknut 1/2" Nyloc	24
9	50069590	U-Bolt 5/8" x 3" x 3 3/8"	16
10	50069631	Hanger Assy	8
11	50069610	Spacer 7 -1/2" Spacing	1
	50069618	Spacer 9" Spacing	1
12	50069616	Washer (Nut End)	1
13	-----	Hex Nut 1"	1
14	-----	Jamb Nut 1" Hex Flat	1
15	50069628	End Cap	4
16	50069632	Gang Tube 45" 6 Blade 7 -1/2" Sp.	1
	50065630	Gang Tube 32" 4 Blade 9" Sp.	1
	50069626	Gang Tube 37" 5 Blade 7 -1/2" Sp.	1
	50069629	Gang Tube 42" 5 Blade 9" Sp.	1
17	50031213	Reflector, Red (Rear Gang Tubes)	2
18	50031212	Reflector, Amber (Front Gang Tubes)	2
19	-----	Locknut 5/8" Nyloc	32
20	-----	Flatwasher 5/8"	32

DISC HARROW 2D SERIES DISC SCRAPERS AND RELATED PARTS

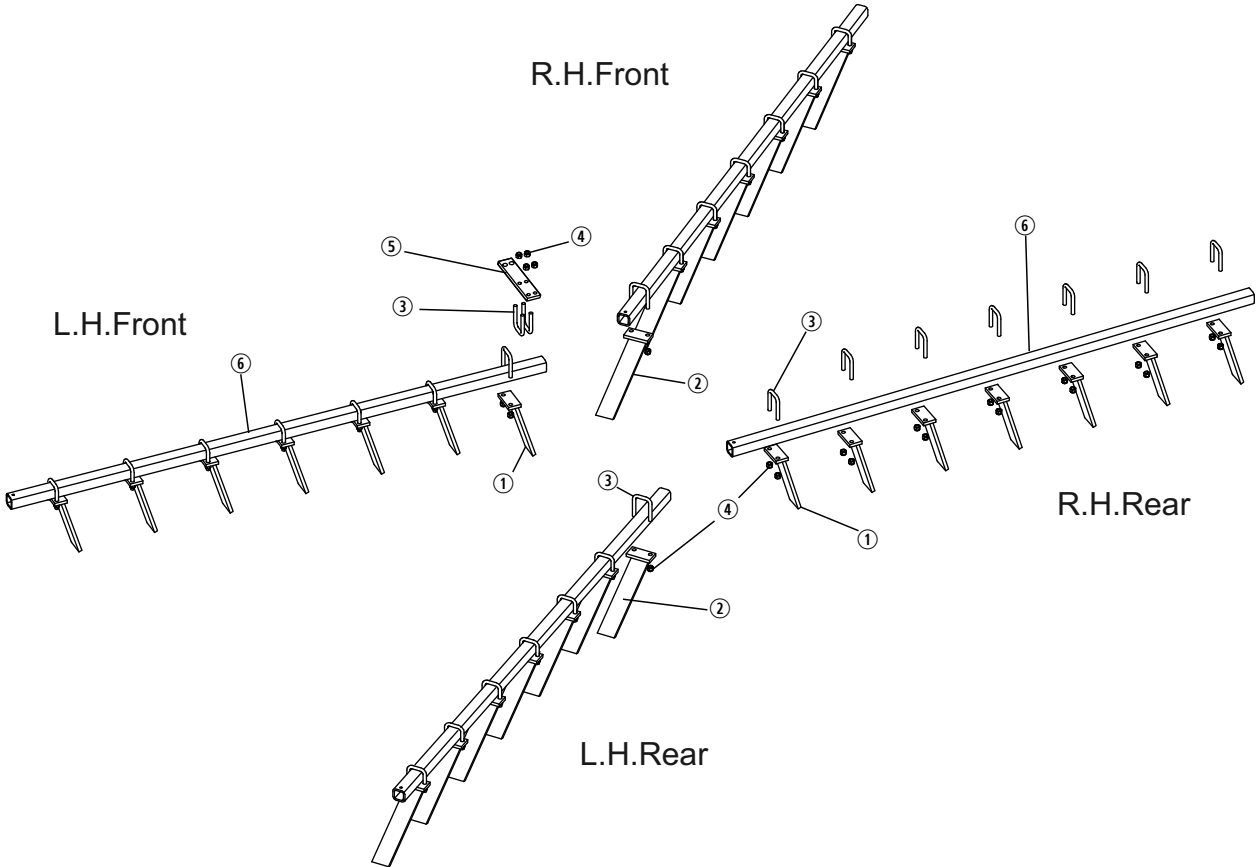

To Order a Complete Scraper Kit for a Complete Machine see the Whole Goods Price List.

Ref. No.	Part No.	Description	Qty. Req'd.
1	50071191	Scraper L.H. Front & R.H. Rear	A/R
2	50071192	Scraper R.H. Front & L.H. Rear	A/R
3	50071188	U-Bolt 3/8" x 1-5/8"	A/R
4	44624BH	Hex Nut 3/8" Nylock	A/R
5	50071190	Scraper Attach Plate	A/R
6	50071194	Scraper Mount Tube 1-1/2" Sq. x 35"	A/R
	50071189	Scraper Mount Tube 1-1/2" Sq. x 43"	A/R

DISC HARROW 3D SERIES FRAME AND RELATED PARTS

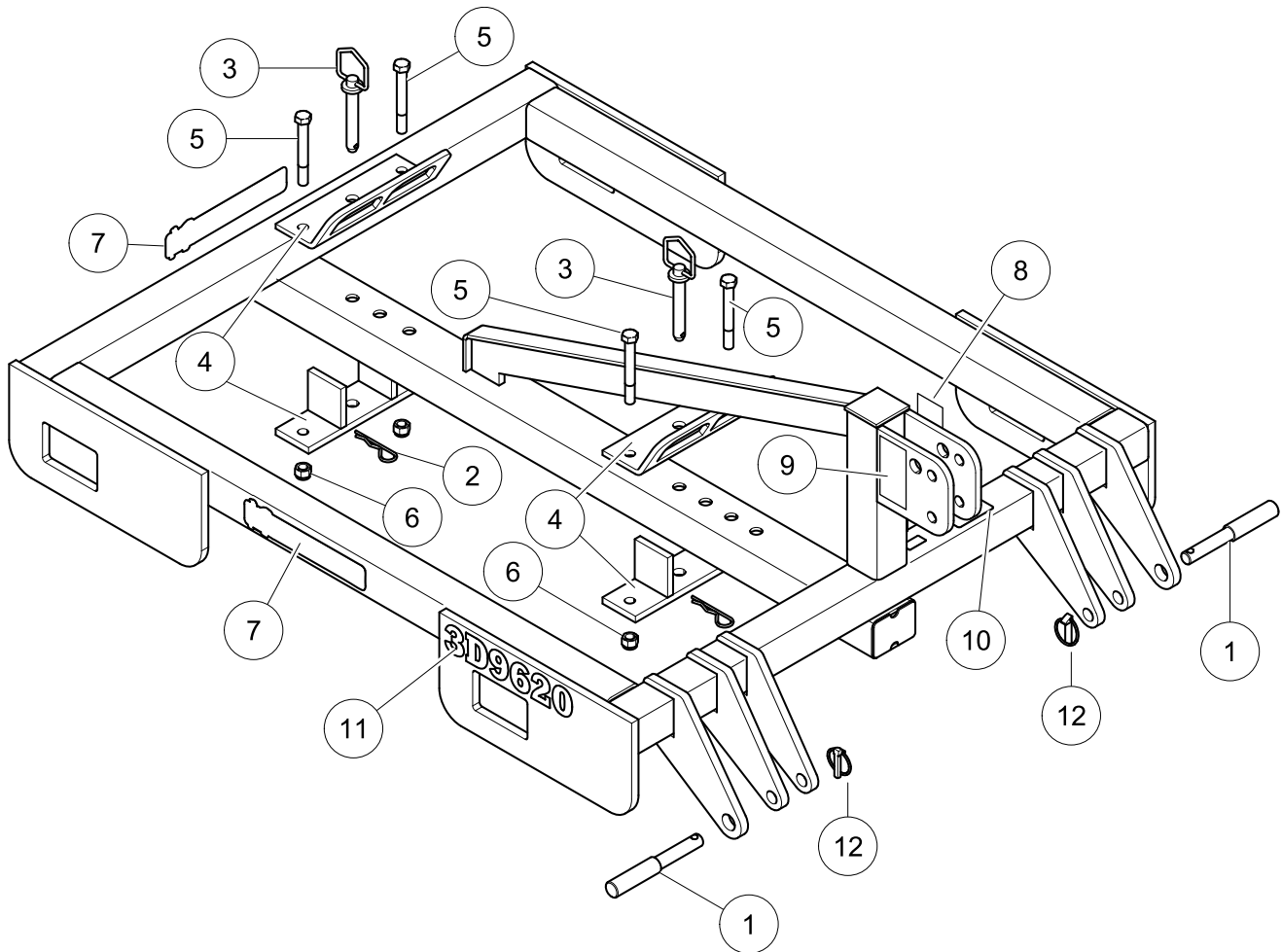

Ref. No.	Part No.	Description	Qty. Req'd.
1	99342	Hitch Pin CAT I / II	2
2	50005860	Hair Pin	2
3	99343	Index Pin 3/4" x 4 1/2"	2
4	5006965	Angle Adj. Assy.	2
5	-----	Cap screw 5/8 x 5" Gr.5	4
6	-----	Locknut 5/8" Nyloc	4
7	50058089	Bush Hog Decal (Logo)	3
8	90960BH	Warning Decal	1
9	50057097	Caution Decal	1
10	00725746	Danger Decal	1
11	50069572	Model Decal 3D9620	2
	50069573	Model Decal 3D9622	2
	50069574	Model Decal 3D11820	2
	50069575	Model Decal 3D11822	2
12	-----	Lynch Pin 7/16"	2

DISC HARROW 3D SERIES DISC GANGS AND RELATED PARTS

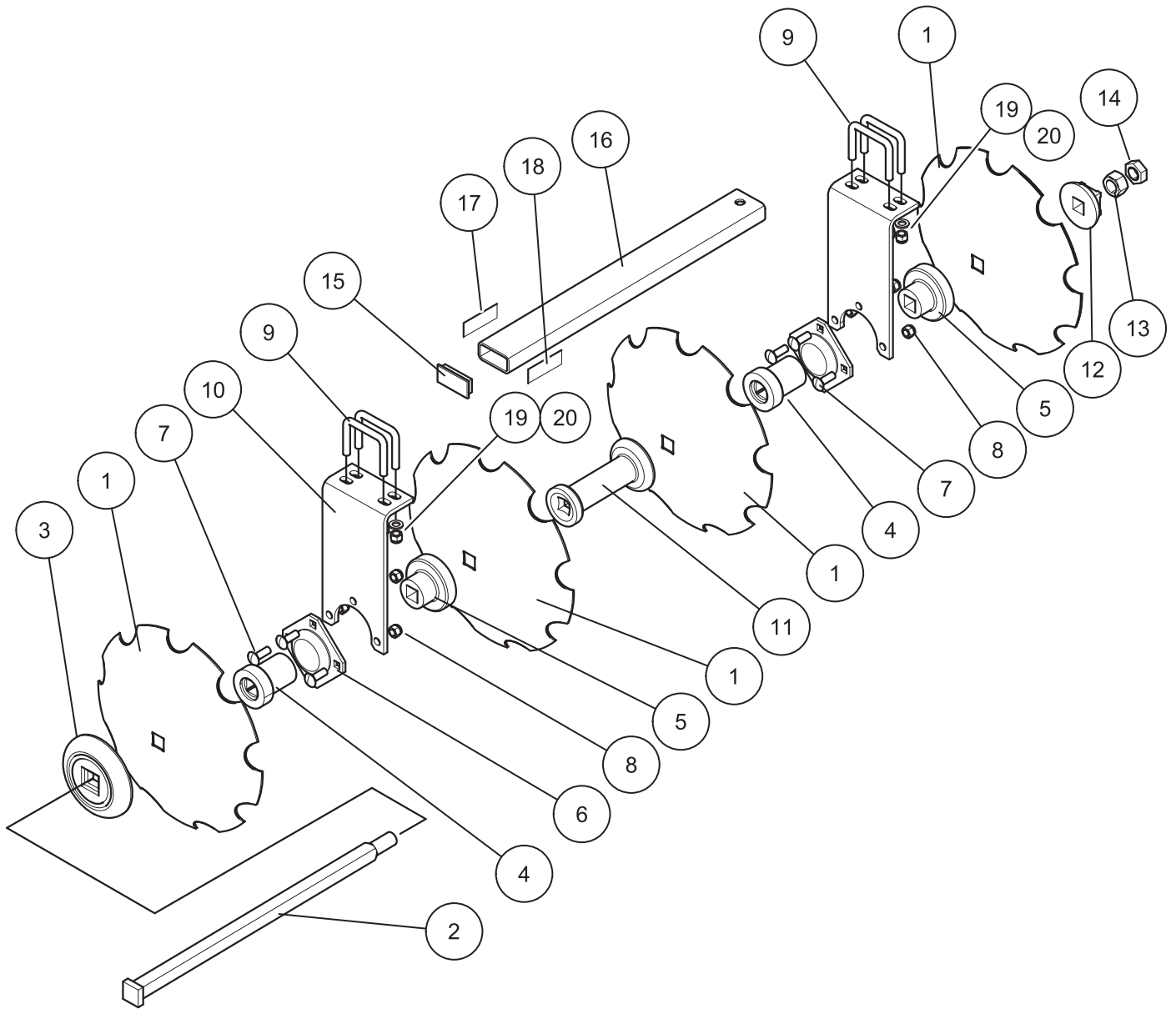

DISC HARROW 3D SERIES DISC GANGS AND RELATED PARTS

Ref. No.	Part No.	Description	Qty. Req'd.
1	50069596	Disc Blade 20" X 3.5mm 1-1/8" Hole	1
	50069604	Disc Blade 22" X 3.5mm 1-1/8" Hole	1
2	50069603	Gang Bolt 1-1/8" x 40-1/4" 5Bld. 9" Sp.	1
	50069601	Gang Bolt 1-1/8" x 42" 6Bld. 7-1/2" Sp.	1
	50069600	Gang Bolt 1-1/8" x 49-1/2" 6 Bld. 9" Sp.	1
	50069600	Gang Bolt 1-1/8" x 49-1/2" 7 Bld. 7-1/2" Sp.	1
3	50069595	Washer (Disc End Cap)	1
4	50069593	Spacer 4-1/2" for 7-1/2" & 9" Spacing	1
5	50069594	Spacer 3-1/4" for 9" Spacing	1
	50069602	Spacer 1-3/4" for 7-1/2" Spacing	1
6	50069597	Bearing	1
7	-----	Carriage Bolt 1/2" x 1-1/2" Gr.5	24
8	-----	Locknut 1/2" Nyloc	24
9	50069589	U-Bolt 5/8" x 4-1/2"	16
10	50069609	Hanger Assy	8
11	50069592	Spacer 7-1/2" Spacing	1
	50069599	Spacer 9" Spacing	1
12	50069598	Washer (Nut End)	1
13	-----	Hex Nut 1-1/8"	1
14	-----	Jamb Nut 1-1/8" Hex Flat	1
15	n/a	End Cap	4
16	50069608	Gang Tube 42" 5 Blade 9" Sp.	1
	50065606	Gang Tube 45" 6 Blade 7-1/2" Sp.	1
	50069607	Gang Tube 52" 6 Blade 9" Sp.	1
	50069607	Gang Tube 52" 7 Blade 7-1/2" Sp.	1
17	50031213	Reflector, Red (Rear Gang Tubes)	2
18	50031212	Reflector, Amber (Front Gang Tubes)	2
19	-----	Locknut 5/8" Nyloc	32
20	-----	Flatwasher 5/8"	32

DISC HARROW 3D SERIES DISC SCRAPERS AND RELATED PARTS

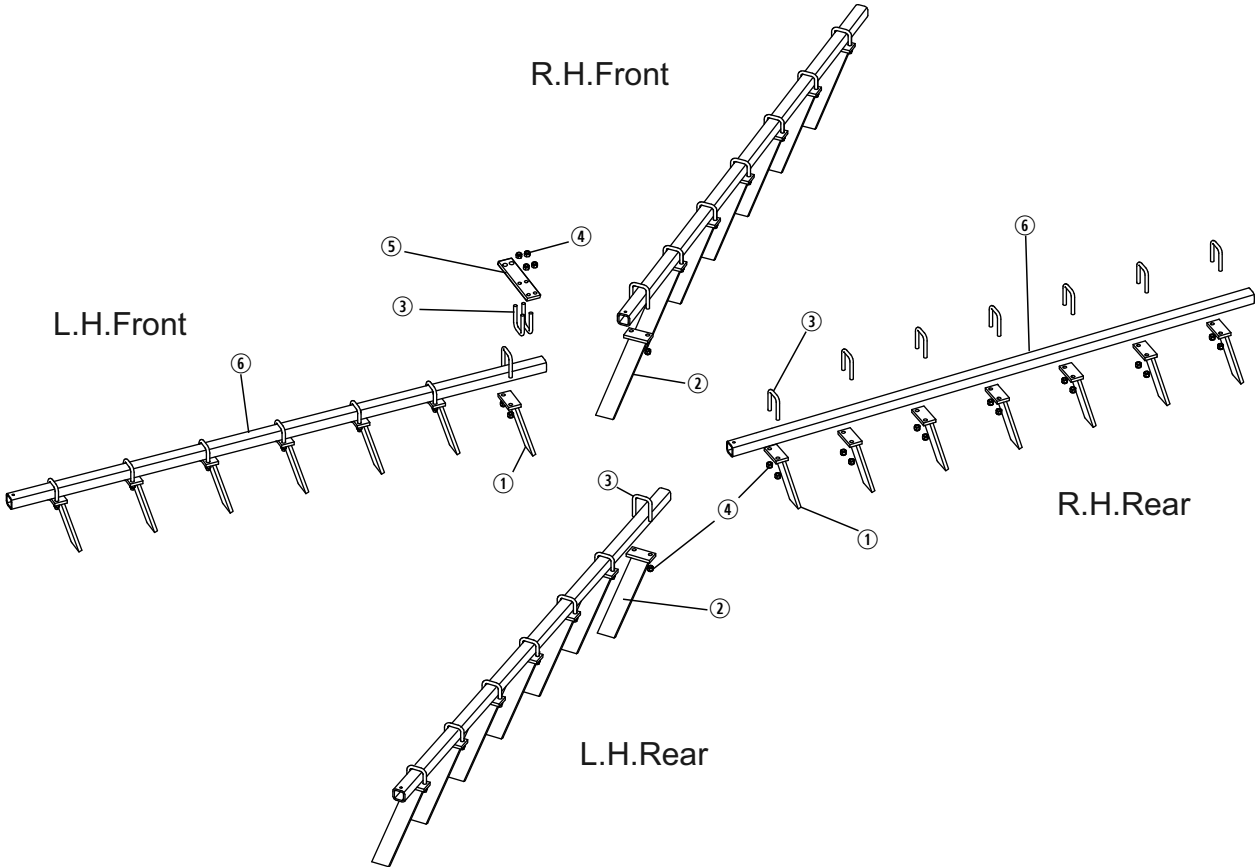

To Order a Complete Scraper Kit for a Complete Machine see the Whole Goods Price List.

Ref. No.	Part No.	Description	Qty. Req'd.
1	50071191	Scraper L.H. Front & R.H. Rear	A/R
2	50071192	Scraper R.H. Front & L.H. Rear	A/R
3	50071188	U-Bolt 3/8" x 1-5/8"	A/R
4	44624BH	Hex Nut 3/8" Nylock	A/R
5	50071190	Scraper Attach Plate	A/R
6	50071193	Scraper Mount Tube 1-1/2" Sq. x 50"	A/R
	50071189	Scraper Mount Tube 1-1/2" Sq. x 43"	A/R

A/R = As Required



BUSH HOG[®]

2501 Griffin Ave. • Selma, AL 36703
(334) 872-6261 • (334) 874-2700
Parts Ordering 1-800-304-2836
Fax 1-800-572-1784
www.bushhog.com